

**RUBBER**



**IMPIEGO  
APPLICATIONS**

Idoneo per mandata e aspirazione di carburanti nelle imbarcazioni e navi da diporto. Particolarmente utilizzato per usi gravosi. Si caratterizza per la sua leggerezza e flessibilità.

Suitable for delivery and suction of fuels on boats and in the light marine industry. Suitable for heavy duties. Flexibility and lightness are a characteristic of this hose.



**STRUTTURA  
BODY**

<b>A</b> <b>Sottostrato Tube</b>	Liscio in gomma nera (NBR) resistente ai carburanti con contenuto aromatico non superiore al 50%. NBR black oil/fuel rubber, smooth, resistant to maximum 50% aromatic contents.
<b>B</b> <b>Inseriti Reinforcement</b>	Tessili, sintetici ad alta tenacità e spirale metallica incorporata. Synthetic yarns fabrics and steel wire.
<b>C</b> <b>Copertura Cover</b>	Mescola in gomma sintetica resistente alla fiamma, ai lubrificanti, ai carburanti all'abrasione, all'acqua di mare ed agli agenti atmosferici. Synthetic rubber compound, flame resistant, abrasion, ozone, weather, heat and oil resistant rubber.
<b>Superficie Surface</b>	Liscia. Smooth.



**FASCETTE E COLLARI STRINGITUBO CONSIGLIATE  
RECOMMENDED CLAMP/COLLAR**

- STF - Fascette a vite Hose clamps with screw (pag. 204-207)
- STC - Fascette con bullone Hose clamps with bolt (pag. 208-210)
- BANDI BLOCK - Coppia di serraggio Tightening torque (pag. 221)



• **Flessibile.**  
Flexible.

• **Raggio di curvatura basso.**  
Low bending radius.

• **Omologato**  
Homologated

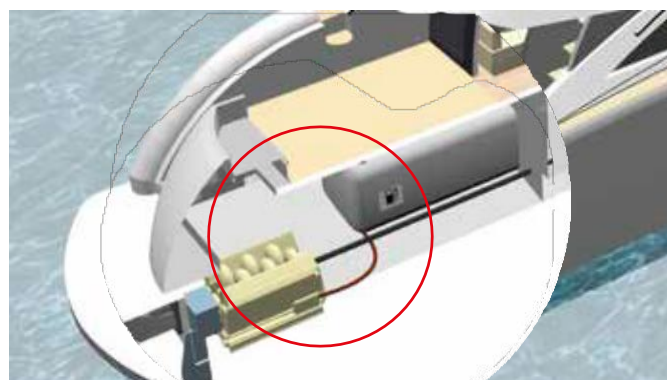

mm	mm	bar	bar	gr/mt	mm	m	
19	31	2,5	10	-0,35	758	90	20
20	32	2,5	10	-0,35	787	100	20
22	34	2,5	10	-0,35	837	110	20
25	37	2,5	10	-0,35	918	125	20
30	42	2,5	10	-0,8	1.087	150	20
32	44	2,5	10	-0,8	1.148	160	20
35	47	2,5	10	-0,8	1.335	175	20
38	50	2,5	10	-0,8	1.433	190	20
40	52	2,5	10	-0,8	1.498	200	20
45	59	2,5	10	-0,8	1.954	223	20
51	63	2,5	10	-0,8	1.942	254	20
60	72	2,5	10	-0,8	2.226	300	20
63	76	2,5	10	-0,8	2.406	318	20



**MARCATURA MARKING:**  
EUROCORD® CARBOMARINE I.D.... EN ISO 7840:2013 A1 E E10/B10

COMPATIBILE R.I.N.A APPROVED - CE - YEAR -  
- FUEL HOSE - SAE J 1527:2011 USCG A1 -  
LLOYD'S APPROVED

**CONFEZIONAMENTO BOX:**  
IMBALLO IN POLIETILENE BLU PACKAGING IN BLUE POLYETHYLENE



**-20°C / +100°C**  
**+4°F / +212°F**