

NEW



UNILIST-BREAK

**NASTRI LISTELLATI CON INSERTO ANTITAGLIO
RIP STOP CHEVRON BELTS**



ULTRA RESISTENTI
grazie all'inserto antitaglio.

ULTRA DURABLE
thanks to the rip stop mesh.

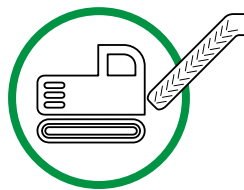

SPECIFICI
per macchine per il trattamento rifiuti,
riciclaggio legno, demolizioni,
smaltimento elettrodomestici, pneumatici.

SPECIFIC
for waste treatment machines,
wood recycling, demolitions,
household waste disposal, tyres recycling.

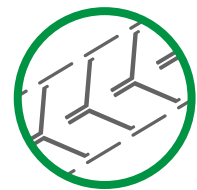

PERSONALIZZABILI
aperti o chiusi ad anello
tramite vulcanizzazione a caldo,
in 10 tipologie di disegno diverse.

TAILOR MADE
open or endless by hot vulcanization
in 10 different versions.



APERTO
OPEN



ANELLO CHIUSO
ENDLESS

UNILIST-BREAK

S15

S25

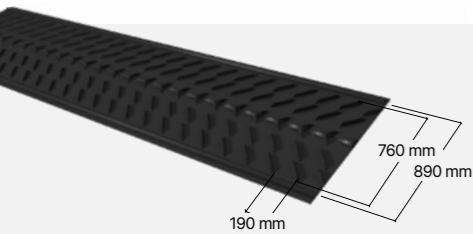

UNILIST BREAK S15 - L890

LARGHEZZE DISPONIBILI
AVAILABLE WIDTHS:
1000/1500 mm

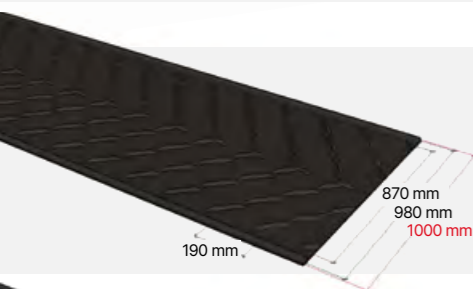
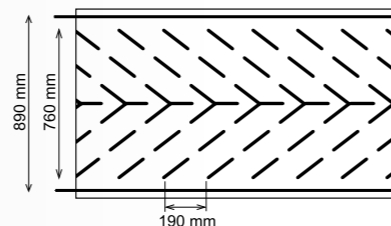

UNILIST BREAK S15 - L980

LARGHEZZE DISPONIBILI
AVAILABLE WIDTHS:
1000/1500 mm

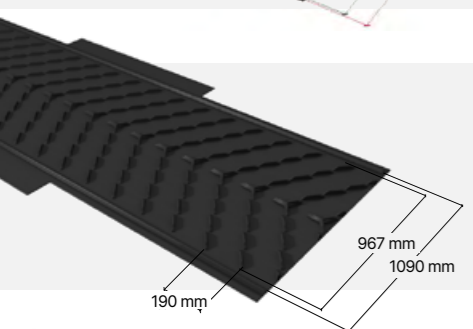
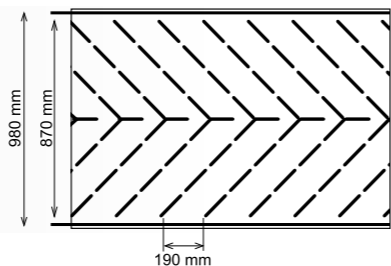

UNILIST BREAK S15 - L1090

LARGHEZZE DISPONIBILI
AVAILABLE WIDTHS:
1200/1400 mm

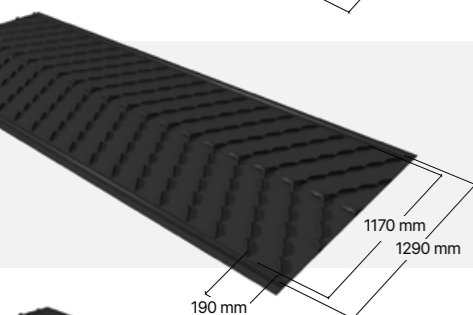
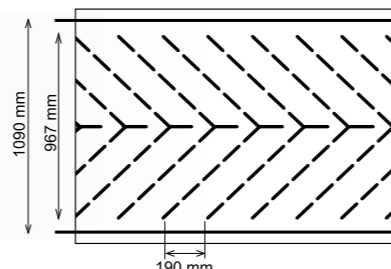

UNILIST BREAK S15 - L1290

LARGHEZZE DISPONIBILI
AVAILABLE WIDTHS:
1400/1500 mm

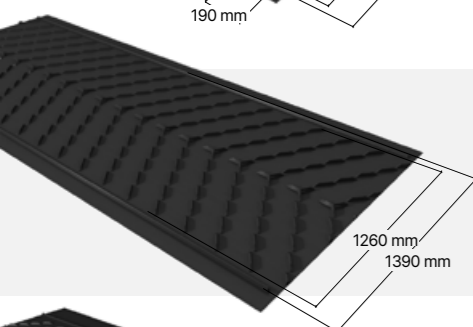
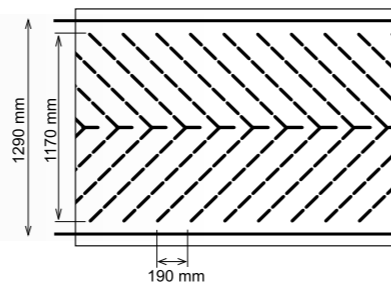

UNILIST BREAK S15 - L1390

LARGHEZZE DISPONIBILI
AVAILABLE WIDTHS:
1500/1600 mm

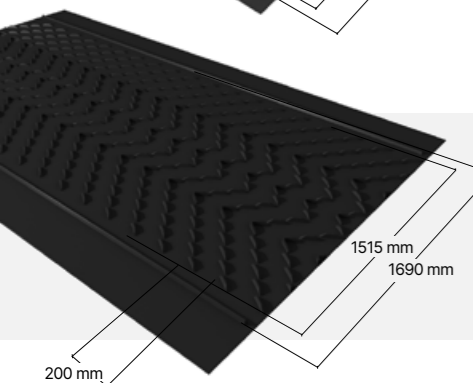
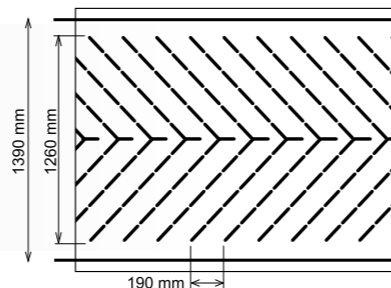

UNILIST BREAK S15 - L1690

LARGHEZZE DISPONIBILI
AVAILABLE WIDTHS:
1800/2200 mm

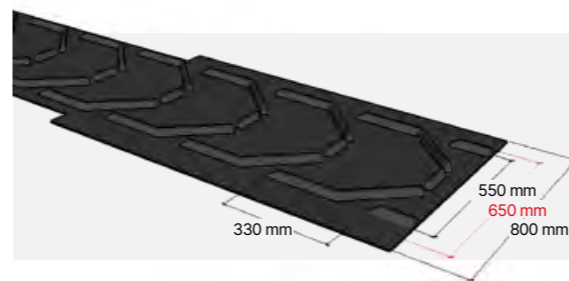
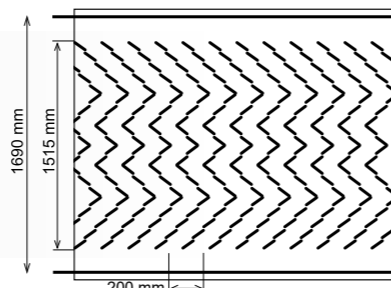

UNILIST BREAK S25 - L990

LARGHEZZE DISPONIBILI
AVAILABLE WIDTHS:
650/1100 mm

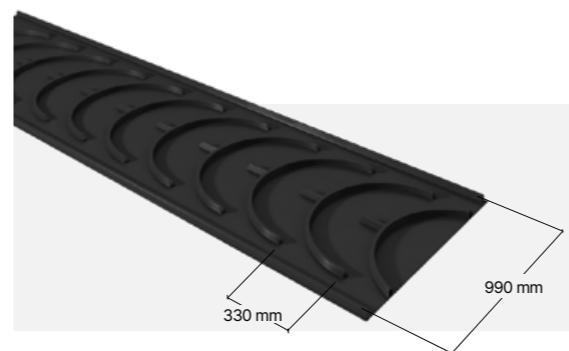
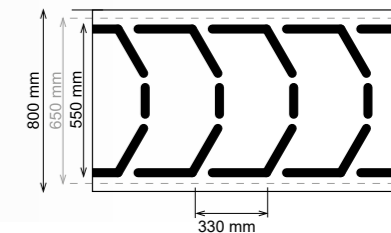

UNILIST BREAK S25 - L990

LARGHEZZE DISPONIBILI
AVAILABLE WIDTHS:
1000/1400 mm

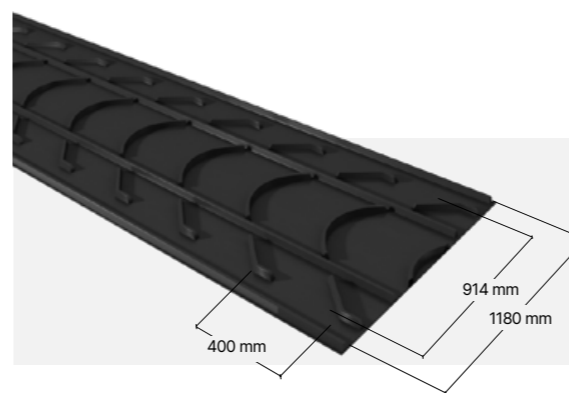
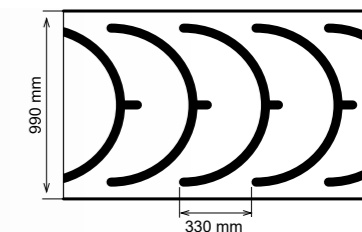

UNILIST BREAK S25 - L1180

LARGHEZZE DISPONIBILI
AVAILABLE WIDTHS:
1200/1400 mm

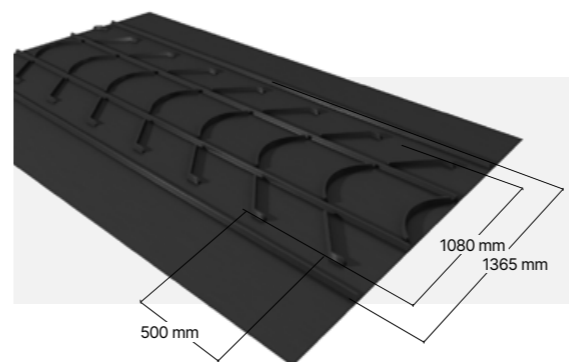
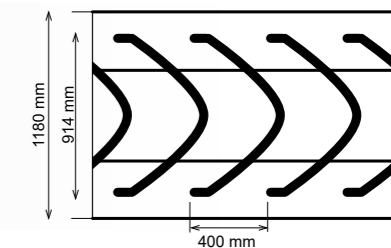

UNILIST BREAK S25 - L1365

LARGHEZZE DISPONIBILI
AVAILABLE WIDTHS:
1400/2200 mm

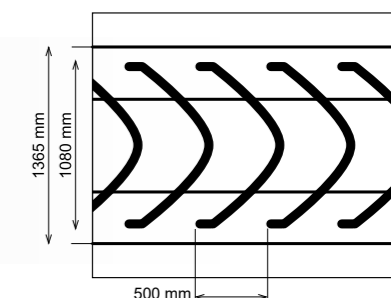

**NASTRI LISTELLATI
CON INSERTO ANTITAGLIO
RIP STOP CHEVRON BELTS**



SCOPRI L'INTERA GAMMA
DI NASTRI TRASPORTATORI.
DISCOVER THE FULL RANGE
OF RUBBER CONVEYOR BELTS.



SATI GROUP S.P.A.

Via Bonazzi, 24
40013 Castel Maggiore
Bologna - Italy
T +39 051 700321
www.satigroup.it

Ufficio Vendite Italia
comercialenastri@satigroup.it

Sales Export Department
export@satigroup.it

P. IVA 00672251204