

NEW



UNILIST-BREAK

**NASTRI LISTELLATI CON INSERTO ANTITAGLIO
RIP STOP CHEVRON BELTS**



ULTRA RESISTENTI
grazie all'inserto antitaglio.

ULTRA DURABLE
thanks to the rip stop mesh.

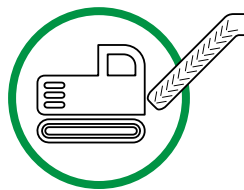

SPECIFICI
per macchine per il trattamento rifiuti,
riciclaggio legno, demolizioni,
smaltimento elettrodomestici, pneumatici.

SPECIFIC
for waste treatment machines,
wood recycling, demolitions,
household waste disposal, tyres recycling.

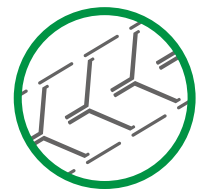

PERSONALIZZABILI
aperti o chiusi ad anello
tramite vulcanizzazione a caldo,
in 8 tipologie di disegno diverse.

TAILOR MADE
open or endless by hot vulcanization
in 8 different versions.



OPEN - ENDLESS



CLOSED IN A RING

UNILIST-BREAK

ASTRI LISTELLATI CON INSERTO ANTITAGLIO RIP STOP CHEVRON BELTS

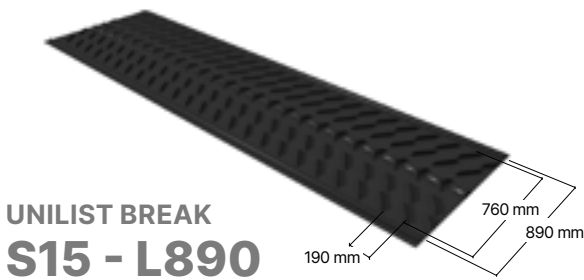

**UNILIST BREAK
S15 - L890**

LARGHEZZE DISPONIBILI AVAILABLE WIDTHS: 1000/1500 mm

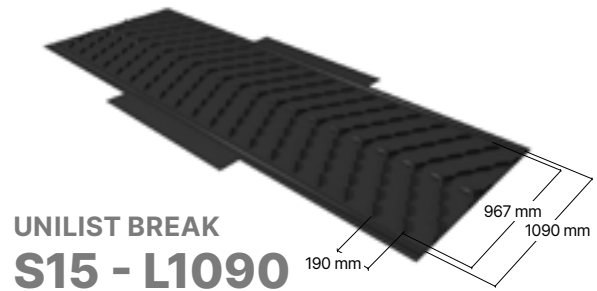

**UNILIST BREAK
S15 - L1090**

LARGHEZZE DISPONIBILI AVAILABLE WIDTHS: 1200/1400 mm

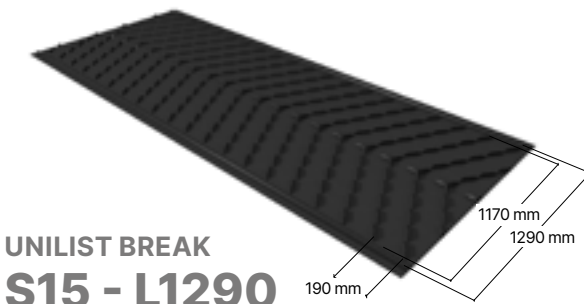

**UNILIST BREAK
S15 - L1290**

LARGHEZZE DISPONIBILI AVAILABLE WIDTHS: 1400/1500 mm

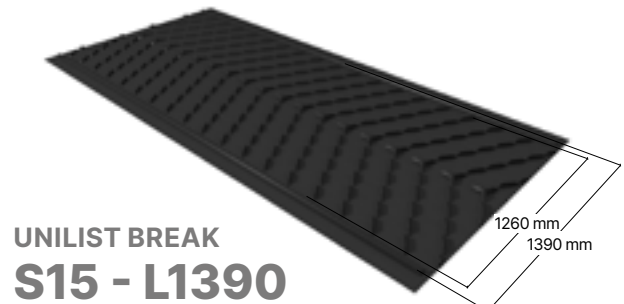

**UNILIST BREAK
S15 - L1390**

LARGHEZZE DISPONIBILI AVAILABLE WIDTHS: 1500/1600 mm

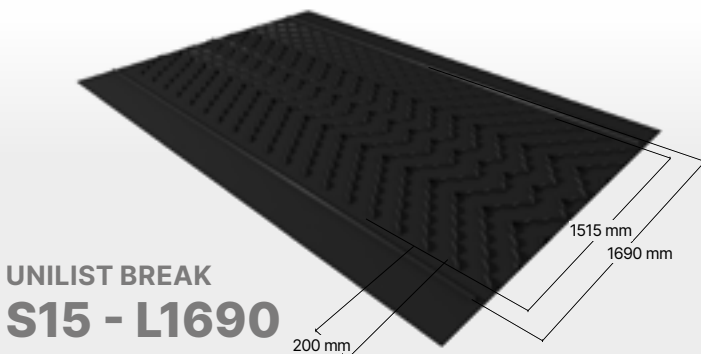

**UNILIST BREAK
S15 - L1690**

LARGHEZZE DISPONIBILI AVAILABLE WIDTHS: 1800/2200 mm

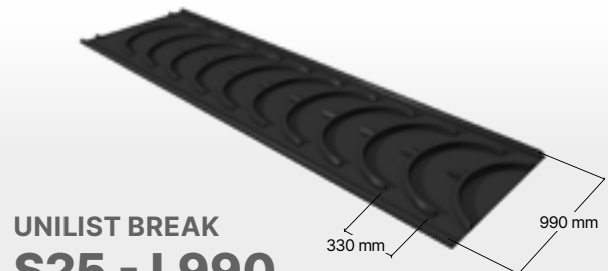

**UNILIST BREAK
S25 - L990**

LARGHEZZE DISPONIBILI AVAILABLE WIDTHS: 1000 mm



**UNILIST BREAK
S25 - L1180**

LARGHEZZE DISPONIBILI AVAILABLE WIDTHS: 1200/1500 mm

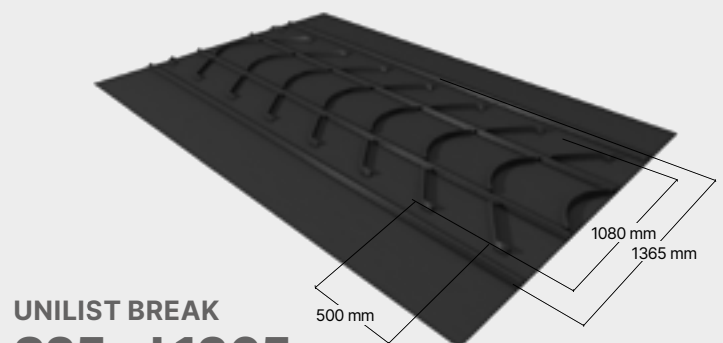

**UNILIST BREAK
S25 - L1365**

LARGHEZZE DISPONIBILI AVAILABLE WIDTHS: 1400/1500 mm

